

RULES FOR JUDGING

A. GENERAL

To rein a horse is not only to guide him, but also to control his every movement. The best reined horse should be willingly guided or controlled with little or no apparent resistance and dictated to completely. Any movement on his own must be considered a lack of control. All deviations from the exact written pattern must be considered a lack of/or temporary loss of control and therefore a fault that must be marked down according to severity of deviation. After deducting all faults, set here within, against execution of the pattern and the horse's overall performance, credit should be given for smoothness, finesse, attitude, quickness and authority of performing various maneuvers, while using controlled speed which raises the difficulty level and makes him more exciting and pleasing to watch to an audience. The official guideline for the application for the rules for judging shall be as specified in the NRHA Judges Guide.

B. SCORING

(1) The scoring will be on a basis of zero (0) to Infinity, with seventy (70) denoting an average performance. The individual maneuvers are scored in one-half ($\frac{1}{2}$) point increments from a low of $-1\frac{1}{2}$ (one and one-half) to a high of $+1\frac{1}{2}$ (one and one-half) with a score of zero (0) denoting a maneuver that is correct with no degree of difficulty. Scores will be announced after each horse works.

(2) **TIES** All ties for 1st place will be worked off if the tied exhibitors agree to participate in a run-off. Tied exhibitors have the alternate option of agreeing not to run-off and to be named co-champions but must determine the winner of the awards by a mutually agreed upon tie-breaker such as a flip of a coin. If they do not agree, the exhibitor(s) who does not want to run-off will forfeit first place to the other. (Exceptions: Freestyle reining. See Freestyle Reining conditions to determine winner or co-champions; Category 2 Snaffle Bit or Hackamore classes—a run-off is not required for 1st place.)

In the case of a tie, the exhibitors or representatives shall be at the gate by the completion of the class to notify show management if they wish to run-off or remain co-champions.

If the riders decide to have a run-off all riders involved in the tie must be present, with their horses, and ready to enter the pen within a maximum of ten minutes after the last horse in the class exits the pen. If one or all of the horses involved in the tie competed within the last five runs of the class, it will be up to the judge's and show management's discretion on the amount of time the rider has before competing in the run-off.

If a tie occurs after the run-off, the entrants will be named co-champions; will evenly split the prize money from their placings, but must determine the winner of the awards by a mutually agreed upon tie-breaker such as a flip of a coin. A horse not returning for a run-off without such an agreement will forfeit 1st place prize money regardless of the added money. In the case of a run-off, the contestant(s) not winning the run-off cannot be placed lower than the lowest position for which he/she was tied, i.e., 2nd/3rd. All other ties are not worked off and will involve as many places as there are horses tied, i.e., 4th, 5th, 6th, 7th. The prize money in the previously mentioned example is added together and split equally-four ways.

(3) Equipment:

(a) Hackamores shall be round in shape and constructed of uniform braided rawhide or leather and have a non-metal flexible core. The noseband of the hackamore must measure at least 5 1/2" of smooth rawhide or leather before any braided buttons, a maximum diameter of 3/4" diameter at the cheek, and be at least 1/2" in diameter. The bosal must be a minimum one finger space (approximately 3/4") between the bosal and nose. Bosals shall be soft and flexible. Absolutely no rigid material will be permitted under the jaws or on the noseband in connection with the bosal, regardless of how padded or covered. Horsehair bosals are prohibited. This rule does not refer to the so-called mechanical hackamore which is illegal.

(b) References to snaffle bits mean conventional O-ring, egg-butt, or D-ring with a ring no larger than 4" and no smaller than 2". The inside circumference of the ring must be free of rein, curb or headstall attachments which would provide leverage. The mouthpiece should be round, oval or egg-shaped, smooth and free of wire. It may be inlaid, but smooth and/or latex wrapped. The bars must be a minimum of 5/16" in diameter, measured 1" in from the cheek with a gradual decrease to center of the snaffle. Optional curb strap is acceptable however curb chains are not acceptable. These requirements remain the same for all classes in which a rider may use a snaffle bit.

(c) References to a bit means the use of a curb bit that has a solid or broken mouthpiece, has shanks and acts with leverage. All curb bits must be free of mechanical device and should be considered a standard western bit. A standard western bit includes:

1. 8 1/2" maximum length shank to be measured as indicated in the judge's guide. Shanks may be fixed or loose.
2. Concerning mouthpieces, bars must be round, oval

or egg-shaped, smooth and free of wire of 5/16" to 3/4" in diameter, measured 1" from the cheek. They may be inlaid, but must be smooth or latex wrapped. Nothing may protrude more than 1/8" below the mouthpiece (bar).

3. The port must be no higher than 3 1/2" maximum, with rollers and covers acceptable. Broken mouthpieces, half-breeds, and spades are standard. Spade bits may have wire wrapped spacer bars.

4. Slip or gag bits, donuts or flat polo mouthpieces are not acceptable.

5. A standard western bit has only one point of pull.

6. Bit Guards

The use of a bit guard is considered legal as long as it is a round disk that is soft and flexible. A standard bit guard is used to gently stop the bit from pinching at the corner of the horse's mouth and is 3.5 inches in diameter. The middle hole should have a 1-inch diameter opening and should not be fixed in any way to the shank of the bit.

(d) Only one hand may be used on the reins and the hand must not be changed, except in the Snaffle Bit, Freestyle, Green, Entry Level Ride & Slide and Para-Reining classes which allow the use of two hands. Green, Entry Level Ride & Slide and Para-Reining classes may use one or two hands at any time during the pattern. Category 2 & 6 aged events may allow the use two hands if all requirements listed in I. Aged Show and Closed Aged Show Conditions are met. When showing one handed, the hand must be held in a traditional western fashion with the palm down and on top of the reins. Index/first finger only, or no fingers, between split reins is permitted at any time. Violation of this rule results in a penalty score of zero (0).

(e) When a curb bit is used, a curb strap or curb chain is required, which must be at least 1/2" in width, lie flat against the jaw, and be free of barbs, wire, and/or twists.

(f) The use of weighted tails is legal. Any device attached directly to the tailbone or that alters the circulation of the tail is prohibited.

(4) The following will result in no score:

(a) infraction of any state or federal law which exists pertaining to the exhibition, care, and custody of horses within the state or country where an NRHA Reining is being held;

(b) abuse of an animal in the show arena and/or evidence that an act of abuse has occurred prior to or during the exhibition of a horse in competition;

(i) if the judge(s) determines paint or other substance has been applied to a horse to disguise abuse he/she

may call a no score. Excessive use of paint or color substance may result in a no score.

(c) use of illegal equipment, including wire on bits, bosals or curb chains;

(d) use of illegal bits, bosals or curb chains;

(e) use of tack collars, tie downs or nose bands;

(f) use of whips or bats;

(g) use of any attachment which alters the circulation of the tail;

(h) use of belly bands, belly wraps, or other materials wrapped around the belly.

(i) failure to dismount and/or present horse and equipment to the appropriate judge for inspection;

(j) In any approved class, the judge shall have the authority to require the removal or alteration of any piece of equipment or accoutrement which is unsafe, or in his/her opinion, would tend to give a horse an unfair advantage or which he/she believes to be inhumane;

(k) disrespect or misconduct by the exhibitor;

(l) the judge(s) may excuse a horse at any time while in the arena for unsafe conditions or improper exhibition pertaining to both the horse and/or rider;

(m) closed reins are not allowed except as standard romal reins and mecates on snaffle bits and bosals in classes where the use of two hands is allowed and in the Youth 10 & Under Short Stirrup, Para-Reining, and Ride & Slide classes where closed reins are allowed.

(n) use of Bluetooth headsets or electronic communication devices in Category 2 & 6 aged events.

(o) failure to wear appropriate western attire as outlined in the *NRHA Handbook*, General Show Conditions.

(5) Excess rein may be straightened anytime during the pattern, provided the rider's free hand remains behind the rein hand. Any attempt to alter tension or length of the reins from bridle to the rein hand is to be considered use of two hands and a penalty score of zero will be applied. In addition, should the judge determine the free hand is being used to instill fear or praise, a penalty five will be applied, and a reduction in the maneuver score. When using a romal, the romal reins can only pass through the hand once, the rider's hand shall be around the reins with the wrist kept straight and relaxed, the thumb on top and the hand closed around the reins; no fingers between the reins are allowed. The free hand may be used to hold the romal provided it is held in a relaxed position and there is at least 16" of romal from the free hand to the reining hand. Use of the free hand while holding the romal to alter the tension or length of the reins from the bridle to the reining

hand is considered to be the use of two hands, and a score of zero (0) will be applied with the exception of any place a horse is allowed to be completely stopped during a pattern. It should be noted that this is also true when using split reins. Tension can be altered with the free hand only by adjusting the tails of the reins when a horse is standing still and only behind the rein hand. A rider must be allowed to untangle or straighten the horse's mane at any place a horse is allowed to be completely stopped during a pattern **without incurring a 5-point penalty.**

(6) The following will result in a \$25 fine:

(a) Failure to display exhibitor number or displaying incorrect exhibitor number

(7) The following will result in a score of zero (0):

(a) use of more than index or first finger between reins;

(b) use of two (2) hands (exception in Snaffle Bit, Hackamore, NRHA Green or Ride & Slide classes designated for two hands) or changing hands;

(c) use of romal other than as outlined in #5;

(d) failure to complete pattern as written;

(e) performing the maneuvers other than in specified order or exceeding greater than one quarter of the circle out of order. Note: See *Judges' Guide* for full explanation;

(f) the inclusion of maneuvers not specified, including, but not limited to

1. backing more than two (2) strides

2. turning more than ninety (90) degrees

3. On run in patterns, once beginning a lope a complete stop prior to reaching the first marker.

(Exception: a complete stop in the 1st quarter (1/4) of a circle after a lope departure is not to be considered an inclusion of maneuver; a two (2) point break of gait penalty will apply.) (See Figure #3B)

(g) equipment failure that delays completion of pattern;

(h) balking or refusal of command where performance is delayed;

(i) running away or failing to guide where it becomes impossible to discern whether the entry is on pattern;

(j) **not being in a lope for** one-half (1/2) circle or one-half (1/2) the length of the arena;

(k) over spins of more than one quarter (1/4) turn;

(l) fall to the ground by horse or rider. A horse is deemed to have fallen when its shoulder and/or hip and/or underline touches the ground;

(m) dropping a rein that contacts the ground while the horse is in motion;

(n) when going to and coming out of a rollback in a pattern requiring a run-around, a rollback that crosses the center line;

NOTE: Neither a no score nor a zero (0) is eligible to place in a go round nor single go round class. Neither a no score nor a zero (0) may advance in a multi-go event. In multi-go events, finals qualifying horses that get a zero (0) or scratch will still be eligible for payouts, with a zero (0) placing higher than a scratch. In the event not enough horses qualify for total purse distribution, the undistributed portion of the purse will be retained by show management.

(8) The following will result in a penalty of five (5) points:

- (a)** spurring in front of cinch;
- (b)** use of either hand to instill fear or praise;
- (c)** Untangling or straightening the latigo or horse's mane when the horse is in motion;
- (d)** holding saddle with either hand;

Exceptions:

1. Freestyle Reining
2. Entry Level
3. Youth 10 & Under Short Stirrup
4. Age 65 and older (Non Pro classes only. Age as of January 1.)

- (e)** the act of a horse dropping to its knees or hocks;
- (f)** blatant disobedience including, but not limited to, kicking, biting, bucking, rearing and striking;

(9) The following will result in a two (2) point penalty:

(a) break of gait; Note: Simple lead changes are allowed in NRHA Green, Ride & Slide, Para-Reining and **Short Stirrup classes**, no break of gait penalty should be applied during the lead change.

(b) freezing up in spins or rollbacks;

(c) on walk in patterns, loping prior to reaching the center of the arena and/or failure to stop or walk before executing a lope departure;

(d) on run in patterns, failure to be in a lope prior to reaching the first marker or break of gait prior to the first marker.

(e) if a horse does not completely pass the specified marker before initiating a stop position.

(10) Starting or performing circles or eights out of lead will be judged as follows:

(a) Each time a horse is out of lead, a judge is required to penalize by one (1) point. The penalty for being out of lead is cumulative, and the judge will add one (1) penalty point for each one quarter ($\frac{1}{4}$) of the circumference of a circle or any part thereof that a horse is out of lead.

(b) A judge is required to penalize a horse one half ($\frac{1}{2}$) of a point for a delayed change of lead by one (1) stride where the lead change is required by the pattern description.

(11) Deduct one half point for starting a circle at a jog or exiting a rollback at a walk or jog up to two (2) strides. Starting

a circle at a jog or exiting a rollback at a walk or jog beyond two (2) strides but less than one half (1/2) circle or one half (1/2) the arena, deduct 2 points.

(12) Deduct one half (1/2) point for over or under spinning up to one eighth (1/8) of a turn; deduct one (1) point for over or under spinning up to one quarter (1/4) of a turn. A horse can only be assessed one over or under spin penalty per maneuver.

(13) In patterns requiring a run-around, failure to be on the correct lead when rounding the end of the arena will be penalized as follows:

(a) From the turn to the half-way position at the end wall: one (1) point

(b) Beyond the half-way point to the beginning of the run down: two (2) points

(14) There will be a one half (1/2) point penalty for failure to remain a minimum of twenty (20) feet from the side of the arena when approaching a stop and/or rollback.

(15) In a pattern requiring a run-around, there will be a one half (1/2) point penalty for failure to remain a minimum of 10 feet from either side of the center of the arena when approaching a stop and/or rollback; for small arenas the distance will be at the judge's discretion.

(16) A horse which severely stumbles, significantly detracting from the maneuver, shall have the maneuver reduced by one half (1/2) point.

(17) Judges may not confer on any penalty or maneuver score prior to submitting a score. If a major penalty (a penalty which results in a no score, a zero (0), a two (2) point, or a five (5) point penalty) is unclear, a judge will submit his/her score and ask that the score be held, pending a conference or review of the official video at the next drag or as soon as practical. Should the judges determine via conference or video replay that a penalty was incurred, it should be applied. If, however, no penalty occurred, the score will be announced as originally submitted. No judge shall be required to change his/her score following a conference or video replay. Each judge's decision is an individual call and based on individual decision from a conference or video replay. The use of video equipment by the judges is only permissible if the judge has reason to believe that all entries have been videotaped. Judges will be allowed to review 2-point penalties for break of gait, jogging more than two (2) strides and freeze ups. Upon the review of a major penalty, if the major penalty is deemed to not have occurred, the judge has the ability to add or remove the appropriate penalty and adjust the maneuver score accordingly. Judges must continue to score no scores and penalty score 0 scores in a multiple judged or videotaped event

in the event of a review. It is suggested that an NRHA judge continue to mark runs whenever possible.

(18) The judge shall have the authority to remove any contestant from a show he is judging, should said contestant show any disrespect or misconduct so as to render himself or the show in an unprofessional manner.

(19) All riders must dismount and the horse must be presented and the bridle dropped by the rider or a designated representative. The horse and equipment must be checked by the designated judge in the arena or in close proximity to the arena during a pre- or post-check. Should the equipment judge detect cause for a no score the exhibitor or his/her representative, trainer or guardian may at that time accept the no score and allow the equipment judge to cause the appropriate changes to all score sheets or request the other judges confer on the appropriate call. In the case of a youth exhibitor, should a parent, trainer or guardian not be present, it will be assumed that all parties are aware of this rule and agree to abide by the exhibitor's decision. If requested, the equipment judge will confer with the other judges as soon as practical. Failure to comply with this rule shall result in a no score.

(20) Judges shall be the sole persons responsible to determine if a rider has correctly completed the pattern as written.

(21) An exhibitor or owner in the respective class may request a review of a major penalty (penalty score zero (0) a two (2) point, or a five (5) point penalty). The judge(s) has the right to deny or honor the request. If honored by the judge(s) he/she must believe the entire class was videotaped by an official videographer. The request must be made no later than thirty (30) minutes after the last run of the day and before the judge(s) has left the grounds for the day. Exhibitors or owners may not have direct contact with the judge(s) during the entire process of requesting a review. The request must be submitted to the Show Steward, Show Representative, or if need be Show management who will take the request to the judge(s).

(22) NRHA permits the judge the option of awarding a re-ride if an unavoidable circumstance disrupts a horse and rider's pattern. In the instance where a re-ride is warranted in the judge's opinion, the judge should advise the NRHA Representative, Steward, and/or horse show management of such as soon as possible. In the case where a horse was able to complete the pattern, but a re-ride is warranted, the score should be held until the rider decides whether to exercise the re-ride option.

(23) The NRHA Judges Committee will evaluate individual requests from challenged riders regarding the use of aids

when exhibiting. In the event an individual is granted special privileges, he or she will be presented said privileges in writing and must provide a copy to the show committee each time he or she exhibits. The Show Committee is required to present said privileges to the Judge(s) as well as the individual's draw number and exhibitor number prior to the class in which he or she will be competing.

(24) Para-Reining Allowances

- 1.** Riders are allowed to choose the size and speed of the circles when it is not specified in the pattern. Excessive speed will result in a maneuver deduction.
- 2.** Riders are allowed to hold the saddle without penalty.
- 3.** Closed reins may be used and include but are not limited to romal, roping, crossed, knotted or taped reins.
- 4.** Riders are allowed to ride with one or two hands at any time during the class.
- 5.** Riders are allowed to use the general provisions included in the list below. Provisions outside of the list below will be handled at the discretion of show management.
 - a.** Specialty braces and/or belts
 - b.** Audio communication equipment
 - c.** Trainer/handler present in the arena
 - d.** Boot adaptations
 - e.** Rein hand holds
 - f.** Rubber bands
 - g.** Saddle blocks
 - h.** Wedges and/or cushions
 - i.** Safety stirrups
 - j.** Seat savers
 - k.** Whips
- 6.** Exemption from dismounting during the pre- and post-check as long as an assistant is present with a halter and lead rope to aide in the pre-check/post-check areas.
- 7.** Exhibitors may use any style bit. The judge stands as the final decision and may deem a bit inhumane and unfit for use in competition.

NOTES

PATTERNS

1. The following patterns are to be worked as stated, not as drawn. The drawn pattern is just to give the general idea of what the pattern will look like in the arena.
2. Markers will be placed on the wall or fence of the arena as follows:
 - (i) at the center of the arena
 - (ii) at least 50' (15 meters) from each end wall
3. Where designated in the pattern for stops to be beyond a marker, the horse should begin his stop after he passes the specified marker.
4. Each pattern is drawn so that the bottom of the page represents the end of the arena entered by contestants and must be run as such. In the event that an arena has only one gate and it is in the exact middle of the side, that side shall represent the right side of the page the pattern is drawn on.
5. All horses will be judged immediately upon entering the arena and judging will cease after the last maneuver. Any fault incurred prior to the commencement of a pattern will be scored according to the rules for judging.
6. All judges' decisions are final.
7. With the exception of Entry Level Ride & Slide & Para-Reining classes, the following patterns are the only patterns to be used at NRHA events. NRHA Green classes should use NRHA patterns but simple lead changes are allowed. Show management hosting Category 11 or 13 classes may request approval from the Executive Committee to use modified patterns following a review and recommendation from the NRHA Judges Committee.

Patterns to follow, ☒ indicates markers

Pattern 1

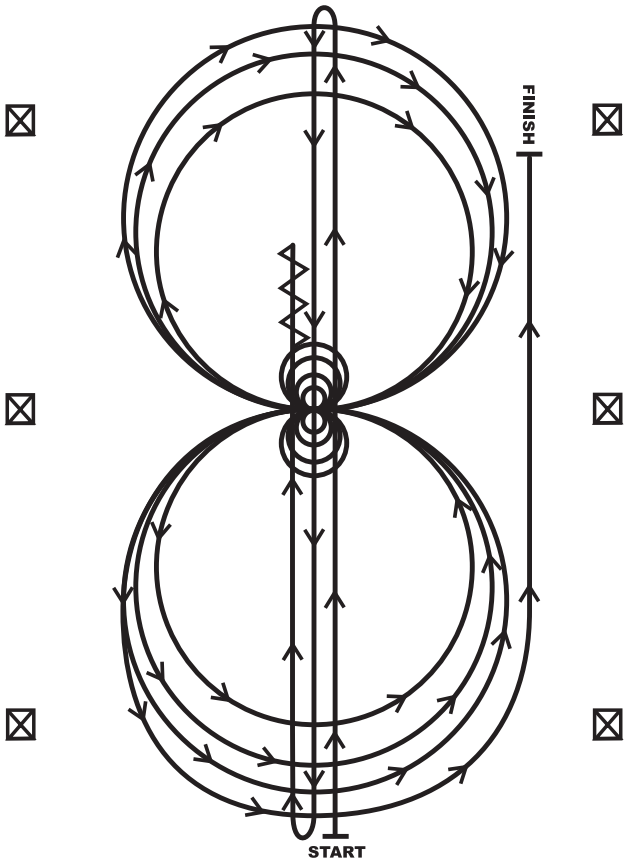

Pattern 1

1. Run at speed to the far end of the arena past the end marker and do a left rollback—no hesitation.
2. Run to the opposite end of the arena past the end marker and do a right rollback—no hesitation.
3. Run past the center marker and do a sliding stop. Back up to center of the arena or at least ten feet (three meters). Hesitate.
4. Complete four spins to the right. Hesitate.
5. Complete four and one-quarter spins to the left so that horse is facing left wall or fence. Hesitate.
6. Beginning on the left lead, complete three circles to the left: the first circle large and fast; the second circle small and slow; the third circle large and fast. Change leads at the center of the arena.
7. Complete three circles to the right: the first circle large and fast; the second circle small and slow; the third circle large and fast. Change leads at the center of the arena.
8. Begin a large circle to the left but do not close this circle. Run straight up the right side of the arena past the center marker and do a sliding stop at least twenty feet (six meters) from wall or fence. Hesitate to demonstrate the completion of the pattern.

Pattern 2

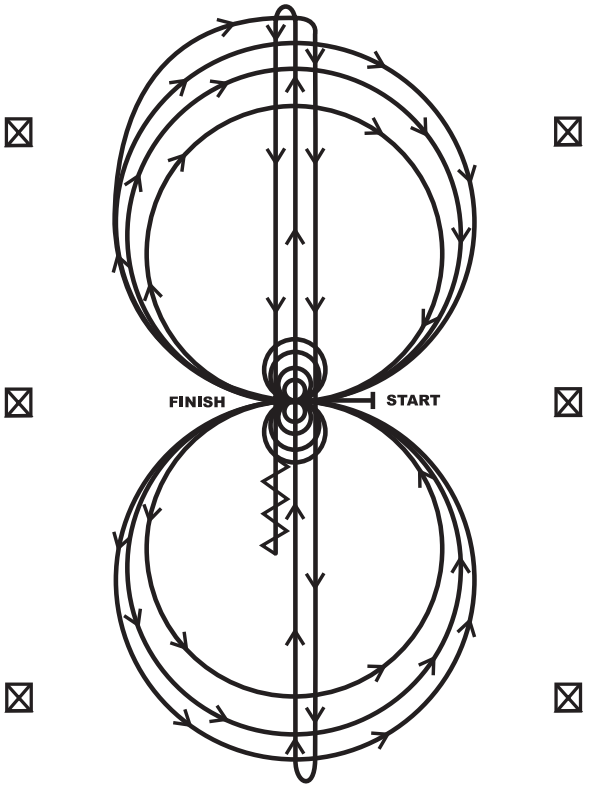

Pattern 2

Horses may walk or jog to the center of arena. (To assist with the show schedule, show management may require that horses be jogged to center. Show management is responsible for posting this requirement.) Horses must walk or stop prior to starting pattern. Beginning at the center of the arena facing the left wall or fence.

1. Beginning on the right lead, complete three circles to the right: the first circle small and slow; the next two circles large and fast. Change leads at the center of the arena.
2. Complete three circles to the left: the first circle small and slow; the next two circles large and fast. Change leads at the center of the arena.
3. Continue around previous circle to the right. At the top of the circle, run down the middle to the far end of the arena past the end marker and do a right rollback—no hesitation.
4. Run up the middle to the opposite end of the arena past the end marker and do a left rollback—no hesitation.
5. Run past the center marker and do a sliding stop. Back up to the center of the arena or at least ten feet (three meters). Hesitate.
6. Complete four spins to the right. Hesitate.
7. Complete four spins to the left. Hesitate to demonstrate the completion of the pattern.

Pattern 3

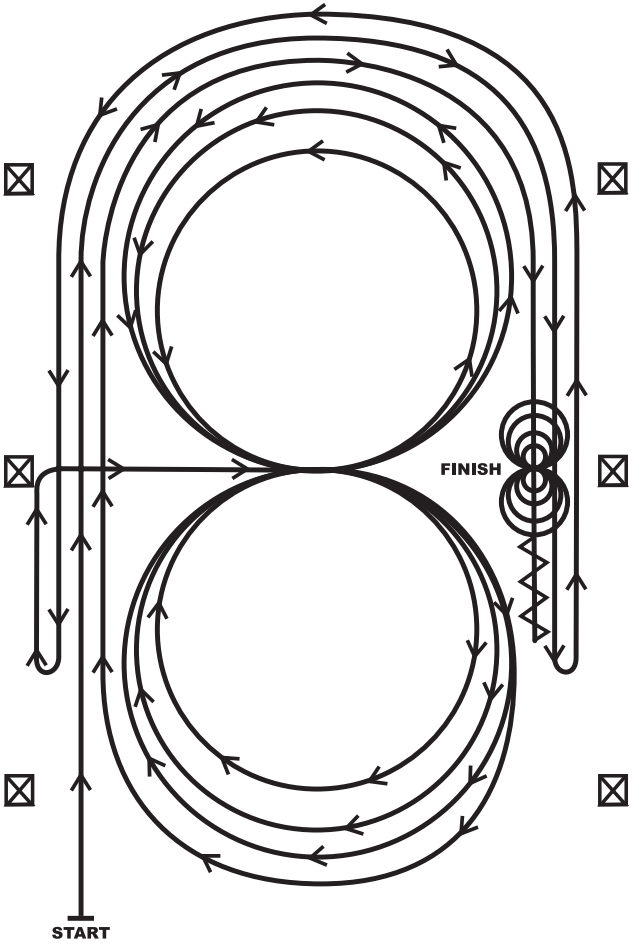

Pattern 3

1. Beginning, lope straight up the left side of the arena, circle the top end of the arena, and staying at least twenty feet (six meters) from the walls or fence, run straight down the opposite or right side of the arena past the center marker and do a left rollback—no hesitation.

2. Continue straight up the right side of the arena circle back around the top of the arena, and staying at least twenty feet (six meters) from the walls or fence, run straight down the left side of the arena past the center marker and do a right rollback—no hesitation.

3. Continue up the left side of the arena to the center marker. At the center marker, the horse should be on the right lead. Guide the horse to the center of the arena on the right lead and complete three circles to the right: the first two circles large and fast; the third circle small and slow. Change leads at the center of the arena.

4. Complete three circles to the left: the first two circles large and fast; the third circle small and slow. Change leads in the center of the arena.

5. Begin a large circle to the right but do not close this circle. Continue up the left side of the arena, circle the top of the arena, and staying at least twenty feet (six meters) from the walls or fence, run straight down the opposite or right side of the arena past the center marker and do a sliding stop. Back up at least ten feet (three meters). Hesitate.

6. Complete four spins to the right. Hesitate.

7. Complete four spins to the left. Hesitate to demonstrate completion of the pattern.

Pattern 4

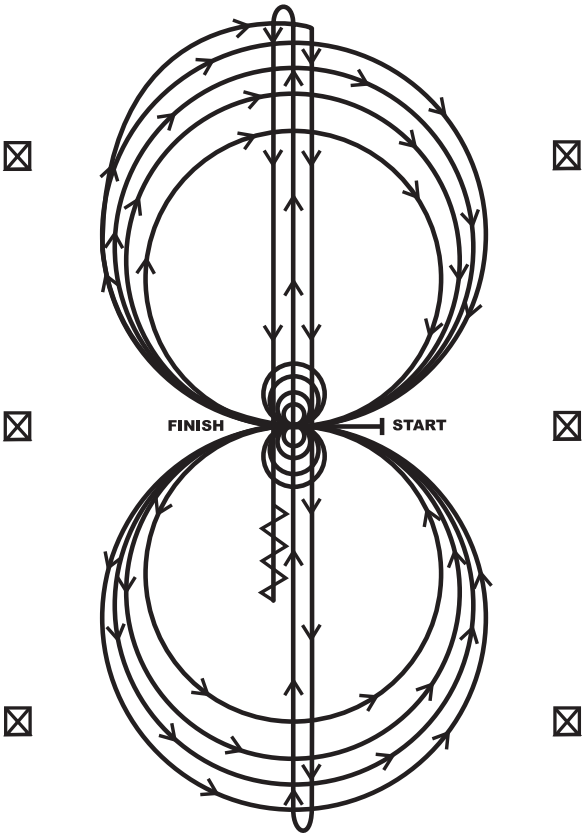

Pattern 4

Horses may walk or jog to the center of the arena. (To assist with the show schedule, show management may require that horses be jogged to center. Show management is responsible for posting this requirement.) Horses must walk or stop prior to starting pattern. Beginning at the center of the arena facing the left wall or fence.

1. Beginning on the right lead, complete three circles to the right: the first two large and fast; the third circle small and slow. Stop at the center of the arena. Hesitate.
2. Complete four spins to the right. Hesitate.
3. Beginning on the left lead, complete three circles to the left: the first two circles large and fast; the third circle small and slow. Stop at the center of the arena. Hesitate.
4. Complete four spins to the left. Hesitate.
5. Beginning on the right lead, run a large fast circle to the right, change leads at the center of the arena, run a large fast circle to the left, and change leads at the center of the arena. (Figure 8)
6. Continue around previous circle to the right. At the top of the circle, run down the middle to the far end of the arena past the end marker and do a right rollback—no hesitation.
7. Run up the middle to the opposite end of the arena past the end marker and do a left rollback—no hesitation.
8. Run past the center marker and do a sliding stop. Back up to the center of the arena or at least ten feet (three meters). Hesitate to demonstrate completion of the pattern.

Pattern 5

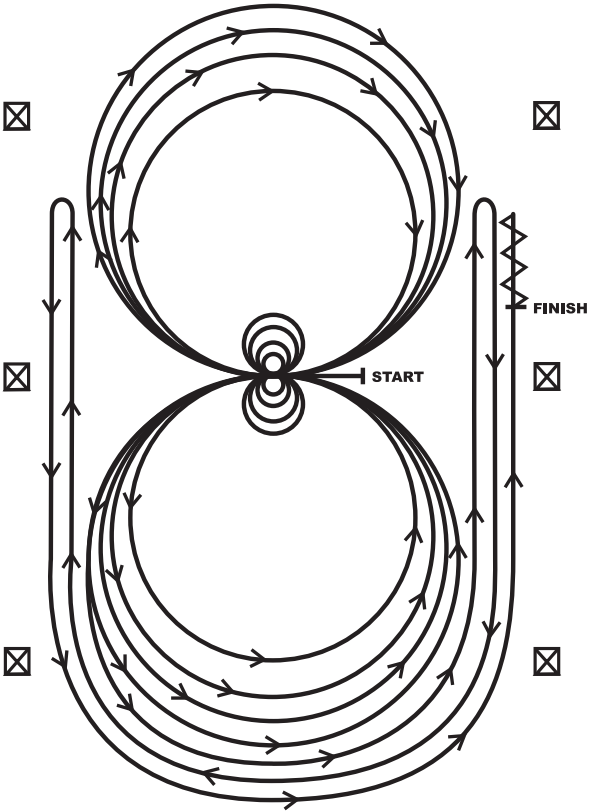

Pattern 5

Horses may walk or jog to the center of arena. (To assist with the show schedule, show management may require that horses be jogged to center. Show management is responsible for posting this requirement.) Horses must walk or stop prior to starting pattern. Beginning at the center of the arena facing the left wall or fence.

1. Beginning on the left lead, complete three circles to the left: the first two circles large and fast; the third circle small and slow. Stop at the center of the arena. Hesitate.
2. Complete four spins to the left. Hesitate.
3. Beginning on the right lead, complete three circles to the right: the first two circles large and fast; the third circle small and slow. Stop at the center of the arena. Hesitate.
4. Complete four spins to the right. Hesitate.
5. Beginning on the left lead, run a large fast circle to the left, change leads at the center of the arena, run a large fast circle to the right, and change leads at the center of the arena. (Figure 8)
6. Continue around previous circle to the left but do not close this circle. Run up the right side of the arena past the center marker and do a right rollback at least twenty feet (six meters) from the wall or fence—no hesitation.
7. Continue around previous circle but do not close this circle. Run up the left side of the arena past the center marker and do a left rollback at least twenty feet (six meters) from the wall or fence—no hesitation.
8. Continue back around previous circle but do not close this circle. Run up the right side of the arena past the center marker and do a sliding stop at least twenty feet (six meters) from the wall or fence. Back up at least ten feet (three meters). Hesitate to demonstrate completion of the pattern.

Pattern 6

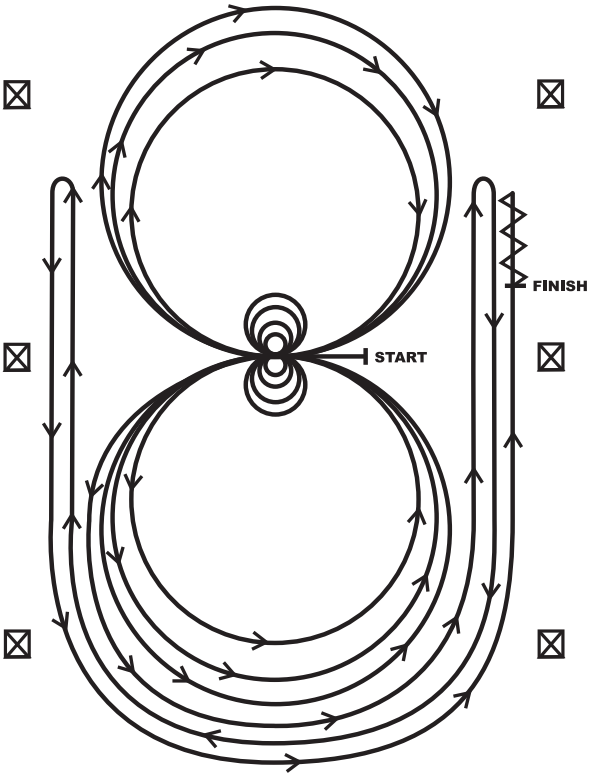

Pattern 6

Horses may walk or jog to the center of arena. (To assist with the show schedule, show management may require that horses be jogged to center. Show management is responsible for posting this requirement.) Horses must walk or stop prior to starting pattern. Beginning at the center of the arena facing the left wall or fence.

1. Complete four spins to the right. Hesitate.
2. Complete four spins to the left. Hesitate.
3. Beginning on the left lead, complete three circles to the left: the first two circles large and fast; the third circle small and slow. Change leads at the center of the arena.
4. Complete three circles to the right: the first two circles large and fast; the third circle small and slow. Change leads at the center of the arena.
5. Begin a large circle to the left but do not close this circle. Run up the right side of the arena past the center marker and do a right rollback at least twenty feet (six meters) from the wall or fence—no hesitation.
6. Continue back around previous circle but do not close this circle. Run up the left side of the arena past the center marker and do a left rollback at least twenty feet (six meters) from the wall or fence—no hesitation.
7. Continue back around previous circle but do not close this circle. Run up the right side of the arena past the center marker and do a sliding stop at least twenty feet (six meters) from the wall or fence. Back up at least ten feet (three meters). Hesitate to demonstrate the completion of the pattern.

Pattern 7

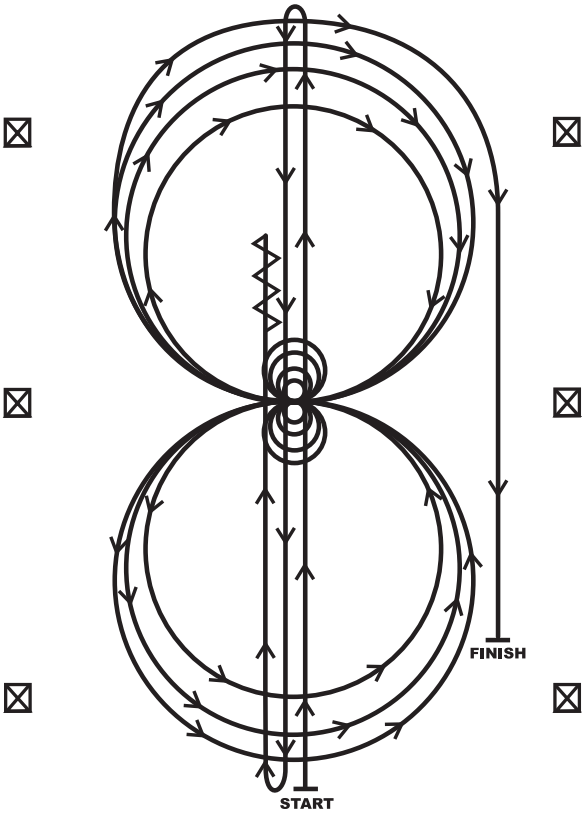

Pattern 7

1. Run at speed to the far end of the arena past the end marker and do a left rollback—no hesitation.
2. Run to the opposite end of the arena past the end marker and do a right rollback—no hesitation.
3. Run past the center marker and do a sliding stop. Back up to the center of the arena or at least ten feet (three meters). Hesitate.
4. Complete four spins to the right. Hesitate.
5. Complete four and one-quarter spins to the left so that horse is facing left wall or fence. Hesitate.
6. Beginning on the right lead, complete three circles to the right: the first two circles large fast; the third circle small and slow. Change leads at the center of the arena.
7. Complete three circles to the left: the first two circles large fast; the third circle small and slow. Change leads at the center of the arena.
8. Begin a large circle to the right but do not close this circle. Run straight down the right side of the arena past the center marker and do a sliding stop at least twenty feet (six meters) from the wall or fence. Hesitate to demonstrate completion of the pattern.

Pattern 8

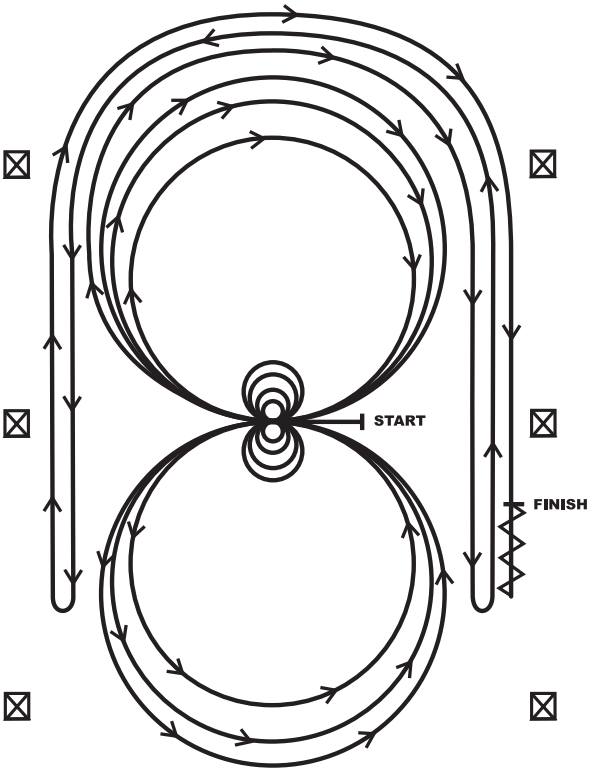

Pattern 8

Horses may walk or jog to the center of arena. (To assist with the show schedule, show management may require that horses be jogged to center. Show management is responsible for posting this requirement.) Horses must walk or stop prior to starting pattern. Beginning at the center of arena facing the left wall or fence.

1. Complete four spins to the left. Hesitate.
2. Complete four spins to the right. Hesitate.
3. Beginning on the right lead, complete three circles to the right: the first circle large and fast; the second circle small and slow; the third circle large and fast. Change leads at the center of the arena.
4. Complete three circles to the left: the first circle large and fast; the second circle small and slow; the third circle large and fast. Change leads at the center of the arena.
5. Begin a large circle to the right but do not close this circle. Run straight down the right side of the arena past the center marker and do a left rollback at least twenty feet (six meters) from the wall or fence—no hesitation.
6. Continue back around the previous circle but do not close this circle. Run down the left side of the arena past the center maker and do a right rollback at least twenty feet (six meters) from the wall or fence—no hesitation.
7. Continue back around the previous circle but do not close this circle. Run down the right side of the arena past the center marker and do a sliding stop at least twenty feet (six meters) from the wall or fence. Back up at least ten feet (three meters). Hesitate to demonstrate completion of the pattern.

Pattern 9

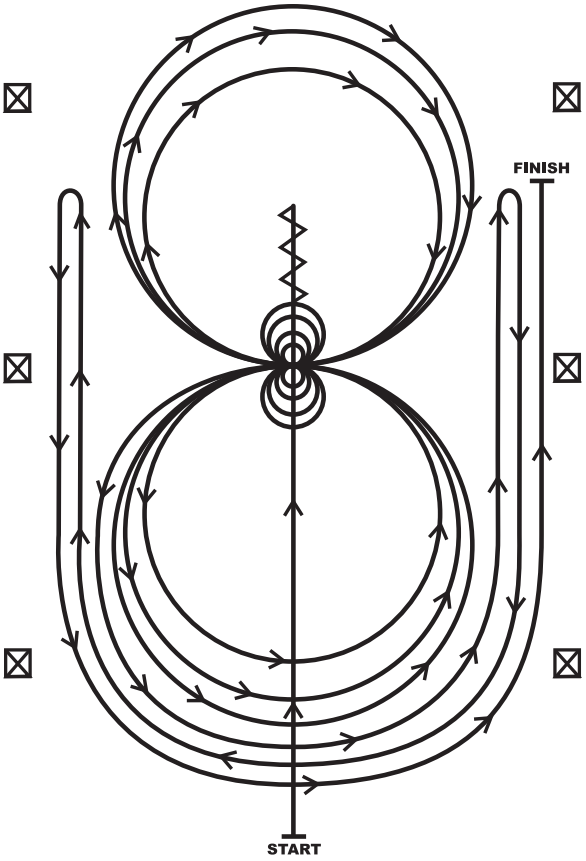

Pattern 9

1. Run past the center marker and do a sliding stop. Back up to the center of the arena or at least ten feet (three meters). Hesitate.
2. Complete four spins to the right. Hesitate.
3. Complete four and one-quarter spins to the left so that horse is facing the left wall or fence. Hesitate.
4. Beginning on the left lead, complete three circles to the left: the first circle small and slow; the next two circles large and fast. Change leads at the center of the arena.
5. Complete three circles to the right: the first circle small and slow; the next two circles large and fast. Change leads at the center of the arena.
6. Begin a large circle to the left but do not close this circle. Run up the right side of the arena past the center marker and do a right rollback at least twenty feet (six meters) from the wall or fence—no hesitation.
7. Continue back around the previous circle but do not close this circle. Run up the left side of the arena past the center marker and do a left rollback at least twenty feet (six meters) from the wall or fence—no hesitation.
8. Continue back around previous circle but do not close this circle. Run up right side of the arena past the center marker and do a sliding stop at least twenty feet (six meters) from the wall or fence. Hesitate to demonstrate completion of the pattern.

Pattern 10

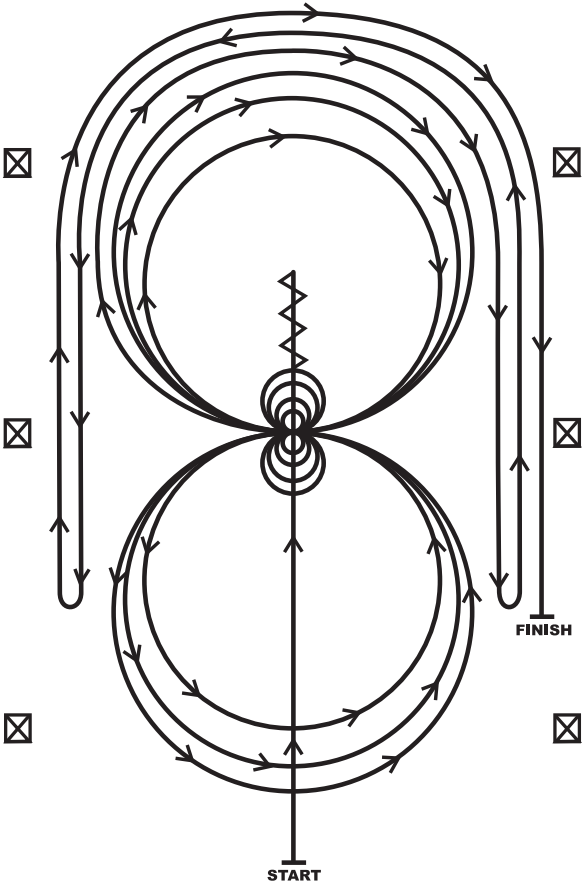

Pattern 10

1. Run past the center marker and do a sliding stop. Back up to the center of the arena or at least ten feet (three meters). Hesitate.
2. Complete four spins to the right. Hesitate.
3. Complete four and one-quarter spins to the left so that the horse is facing the left wall or fence. Hesitate.
4. Beginning on the right lead, complete three circles to the right: the first two circles large and fast, the third circle small and slow. Change leads at the center of the arena.
5. Complete three circles to the left: the first circle small and slow, the next two circles large and fast. Change leads at the center of the arena.
6. Begin a large circle to the right but do not close this circle. Run down the right side of the arena past the center marker and do a left rollback at least twenty feet (six meters) from the wall or fence—no hesitation.
7. Continue back around the previous circle but do not close this circle. Run down the left side of the arena past the center and do a right rollback at least twenty feet (six meters) from the wall or fence—no hesitation.
8. Continue back around previous circle but do not close this circle. Run down the right side of the arena past the center marker and do a sliding stop at least twenty feet (six meters) from the wall or fence. Hesitate to demonstrate completion of the pattern.

Pattern 11

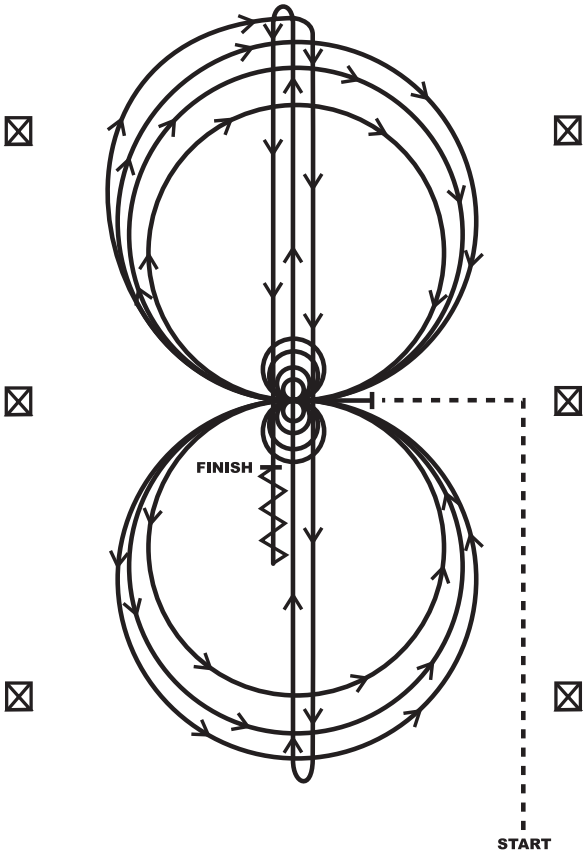

Pattern 11

Horses must jog to the center of the arena (see Judges Guide for maneuver description). Horses must walk or stop prior to starting the pattern. Beginning at the center of the arena facing the left wall or fence.

1. Complete four spins to the left. Hesitate.
2. Complete four spins to the right. Hesitate.
3. Beginning on the right lead complete three circles to the right; the first circle small and slow; the next two circles large and fast. Change leads at the center of the arena.
4. Complete three circles to the left; the first circle small and slow; the next two circles large and fast. Change leads at the center of the arena.
5. Begin a large circle to the right, but do not close this circle. Run down the center of the arena past the end marker and do a right rollback—no hesitation.
6. Run up the middle to the opposite end of the arena past the end marker and do a left rollback—no hesitation.
7. Run past the center marker and do a sliding stop. Back up to the center of the arena or at least ten feet (three meters). Hesitate to demonstrate completion of the pattern.

Pattern 12

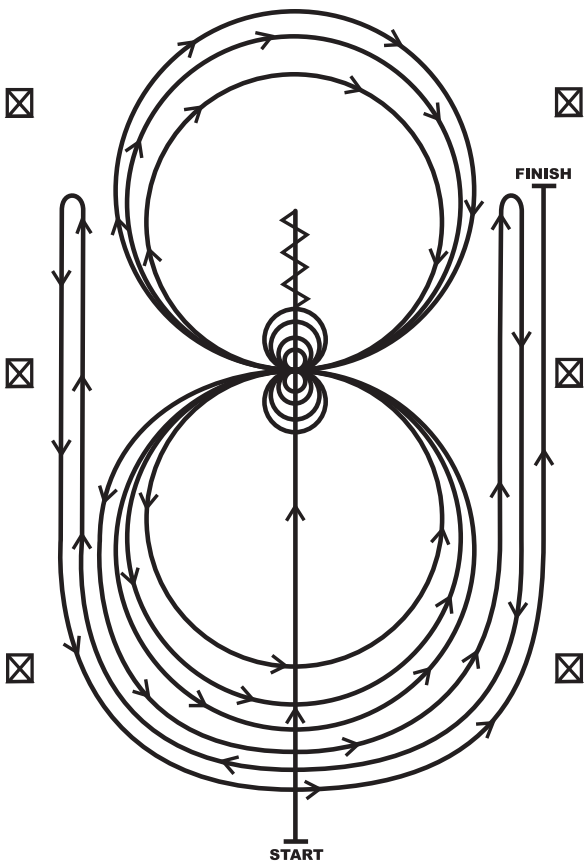

Pattern 12

1. Run past the center marker and do a sliding stop. Back up to the center of the arena or at least 10 feet (3 meters). Hesitate.
2. Complete four spins to the right. Hesitate.
3. Complete four and one-quarter spins to the left so that the horse is facing the left wall or fence. Hesitate.
4. Beginning on the left lead, complete three circles to the left: the first two circles large and fast; the third circle small and slow. Change leads at the center of the arena.
5. Complete three circles to the right: the first two circles large and fast; the third circle small and slow. Change leads at the center for the arena.
6. Begin a large circle to the left but do not close this circle. Run up the right side of the arena past the center marker and do a right rollback at least 20 feet (6 meters) from the wall or fence-no hesitation.
7. Continue back around previous circle but do not close this circle. Run up the left side of the arena and past the center marker and do a left rollback at least 20 feet (6 meters) from the wall or fence-no hesitation.
8. Continue back around previous circle but do not close this circle. Run up the right side of the arena past the center marker and do a sliding stop at least 20 feet (6 meters) from the wall or fence. Hesitate to demonstrate completion of pattern.

Pattern 13

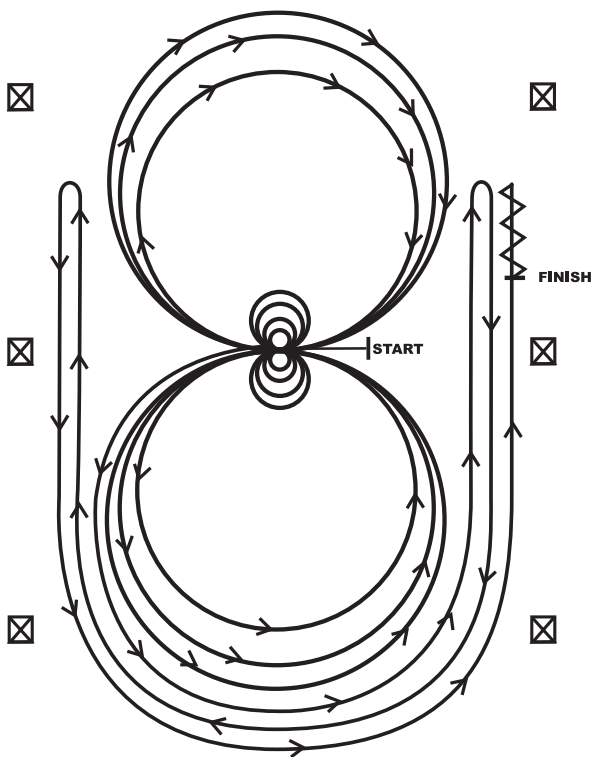

Pattern 13

Horses may walk or jog to the center of the arena. (To assist with the show schedule, show management may require that horses be jogged to center. Show management is responsible for posting this requirement.) Horses must walk or stop prior to starting pattern. Beginning at the center of the arena facing the left wall or fence.

1. Beginning on the left lead, complete two circles to the left: the first circle large and fast; the second circle small and slow. Stop at the center of the arena. Hesitate.
2. Complete four spins to the left. Hesitate.
3. Beginning on the right lead, complete two circles to the right: the first being large and fast; the second circle small and slow. Stop at the center of the arena. Hesitate.
4. Complete four spins to the right. Hesitate.
5. Beginning on the left lead, run a large fast circle to the left, change leads at the center of the arena, run a large fast circle to the right, and change leads at the center of the arena (figure 8).
6. Continue around previous circle to the left but do not close this circle. Run up the right side of the arena past the center marker and do a right rollback at least 20 feet (6meters) from the wall or fence-no hesitation.
7. Continue around previous circle but do not close this circle. Run up the left side of the arena past the center marker and do a left rollback at least 20 feet (6 meters) from the wall or fence-no hesitation.
8. Continue back around previous circle but do not close this circle. Run up the right side of the arena past the center marker and do a sliding stop at least 20 feet (6 meters) from the wall or fence. Back up at least 10 feet (3 meters). Hesitate to demonstrate completion of pattern.

Pattern 14

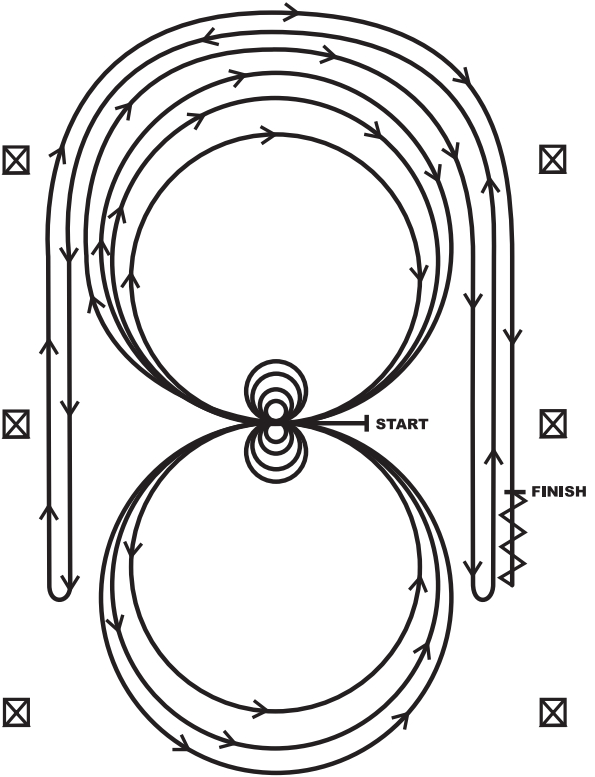

Pattern 14

Horses may walk or jog to the center of arena. (To assist with the show schedule, show management may require that horses be jogged to center. Show management is responsible for posting this requirement.) Horses must walk or stop prior to starting pattern. Beginning at the center of the arena facing the left wall or fence.

1. Complete four spins to the left. Hesitate.
2. Complete four spins to the right. Hesitate.
3. Beginning on the right lead, complete three circles to the right: the first two circles large and fast; the third circle small and slow. Change leads at the center of the arena.
4. Complete three circles to the left: the first two circles large and fast; the third circle small and slow. Change leads at the center of the arena.
5. Begin a large circle to the right but do not close this circle. Run up the right side of the arena past the center marker and do a left rollback at least twenty feet (six meters) from the wall or fence—no hesitation.
6. Continue back around previous circle but do not close this circle. Run up the left side of the arena past the center marker and do a right rollback at least twenty feet (six meters) from the wall or fence—no hesitation.
7. Continue back around previous circle but do not close this circle. Run up the right side of the arena past the center marker and do a sliding stop at least twenty feet (six meters) from the wall or fence. Back up at least ten feet (three meters). Hesitate to demonstrate the completion of the pattern.

Pattern 15

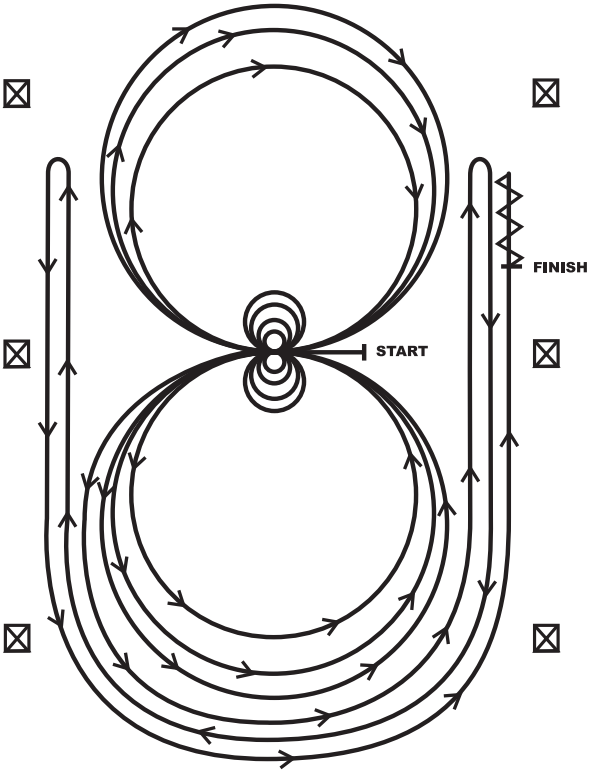

Pattern 15

Horses may walk or jog to the center of arena. (To assist with the show schedule, show management may require that horses be jogged to center. Show management is responsible for posting this requirement.) Horses must walk or stop prior to starting pattern. Beginning at the center of arena facing the left wall or fence.

1. Complete four spins to the right. Hesitate.
2. Complete four spins to the left. Hesitate.
3. Beginning on the left lead, complete three circles to the left: the first circle large and fast; the second circle small and slow; the third circle large and fast. Change leads at the center of the arena.
4. Complete three circles to the right: the first circle large and fast; the second circle small and slow; the third circle large and fast. Change leads at the center of the arena.
5. Begin a large circle to the left but do not close this circle. Run straight down the right side of the arena past the center marker and do a right rollback at least twenty feet (six meters) from the wall or fence—no hesitation.
6. Continue back around the previous circle but do not close this circle. Run down the left side of the arena past the center maker and do a left rollback at least twenty feet (six meters) from the wall or fence—no hesitation.
7. Continue back around the previous circle but do not close this circle. Run down the right side of the arena past the center marker and do a sliding stop at least twenty feet (six meters) from the wall or fence. Back up at least ten feet (three meters). Hesitate to demonstrate completion of the pattern.

Pattern 16

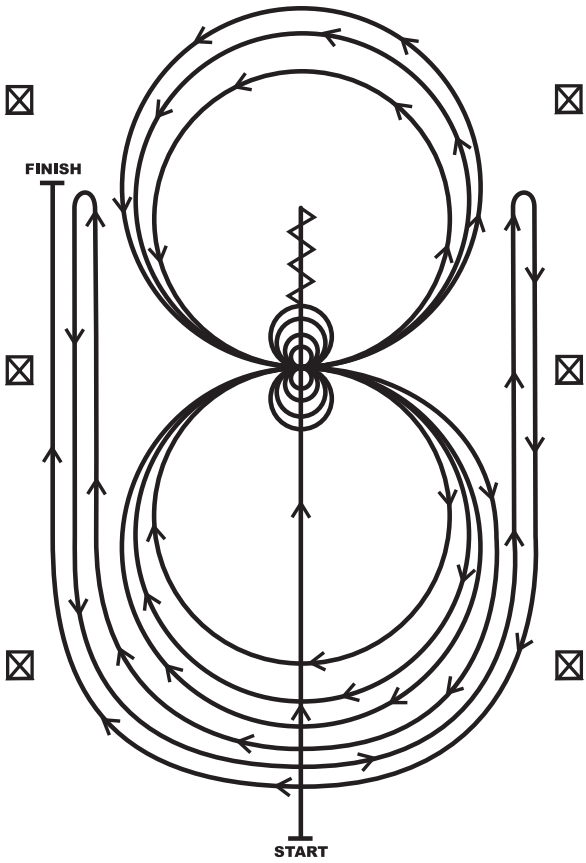

Pattern 16

1. Run past the center marker and do a sliding stop. Back up to the center of the arena or at least 10 feet (3 meters). Hesitate.
2. Complete four spins to the left. Hesitate.
3. Complete four and one-quarter spins to the right so that the horse is facing the right wall or fence. Hesitate.
4. Beginning on the right lead, complete three circles to the right: the first two circles large and fast; the third circle small and slow. Change leads at the center of the arena.
5. Complete three circles to the left: the first two circles large and fast; the third circle small and slow. Change leads at the center for the arena.
6. Begin a large circle to the right but do not close this circle. Run up the left side of the arena past the center marker and do a left rollback at least 20 feet (6 meters) from the wall or fence-no hesitation.
7. Continue back around previous circle but do not close this circle. Run up the right side of the arena and past the center marker and do a right rollback at least 20 feet (6 meters) from the wall or fence-no hesitation.
8. Continue back around previous circle but do not close this circle. Run up the left side of the arena past the center marker and do a sliding stop at least 20 feet (6 meters) from the wall or fence. Hesitate to demonstrate completion of pattern.

Pattern 17

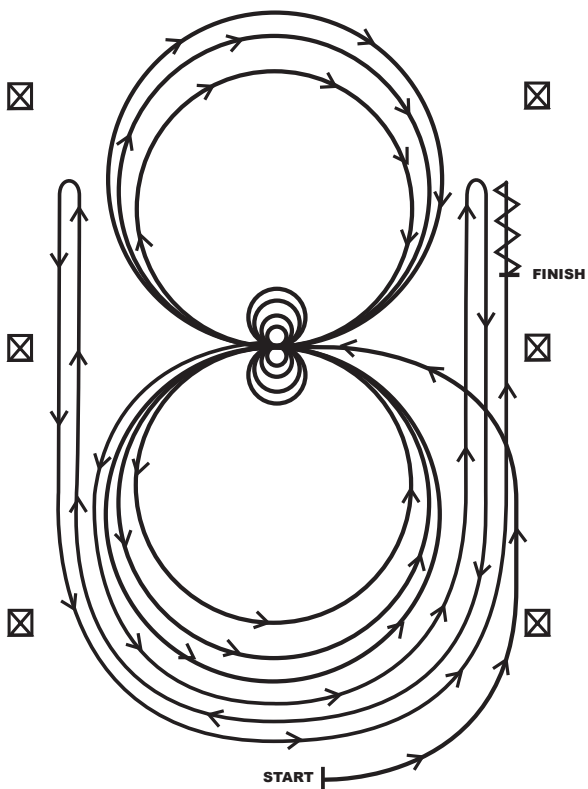

Pattern 17

Begin on the left lead. Continue to the center of the arena to begin the pattern facing toward the left wall or fence, without stopping or breaking gait.

1. Continue on the left lead, complete two circles to the left: the first circle large and fast; the second circle small and slow. Stop at the center of the arena. Hesitate.
2. Complete four spins to the left. Hesitate.
3. Beginning on the right lead, complete two circles to the right: the first being large and fast; the second circle small and slow. Stop at the center of the arena. Hesitate.
4. Complete four spins to the right. Hesitate.
5. Beginning on the left lead, run a large fast circle to the left, change leads at the center of the arena, run a large fast circle to the right, and change leads at the center of the arena (figure 8).
6. Continue around previous circle to the left but do not close this circle. Run up the right side of the arena past the center marker and do a right rollback at least 20 feet (6 meters) from the wall or fence-no hesitation.
7. Continue around previous circle but do not close this circle. Run up the left side of the arena past the center marker and do a left rollback at least 20 feet (6 meters) from the wall or fence-no hesitation.
8. Continue back around previous circle but do not close this circle. Run up the right side of the arena past the center marker and do a sliding stop at least 20 feet (6 meters) from the wall or fence. Back up at least 10 feet (3 meters). Hesitate to demonstrate completion of pattern.

Pattern 18

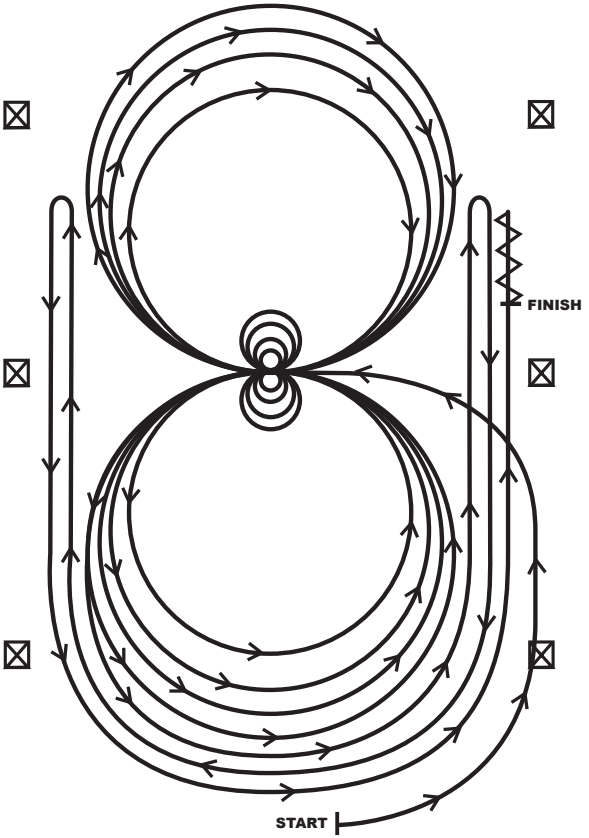

Pattern 18

Begin on the left lead. Continue to the center of the arena to begin the pattern facing toward the left wall or fence, without stopping or breaking gait.

1. Continue on the left lead, complete three circles to the left: the first two circles large and fast; the third circle small and slow. Stop at the center of the arena. Hesitate.
2. Complete four spins to the left. Hesitate.
3. Beginning on the right lead, complete three circles to the right: the first two circles large and fast; the third circle small and slow. Stop at the center of the arena. Hesitate.
4. Complete four spins to the right. Hesitate.
5. Beginning on the left lead, run a large fast circle to the left, change leads at the center of the arena, run a large fast circle to the right, and change leads at the center of the arena. (Figure 8)
6. Continue around previous circle to the left but do not close this circle. Run up the right side of the arena past the center marker and do a right rollback at least twenty feet (six meters) from the wall or fence—no hesitation.
7. Continue around previous circle but do not close this circle. Run up the left side of the arena past the center marker and do a left rollback at least twenty feet (six meters) from the wall or fence—no hesitation.
8. Continue back around previous circle but do not close this circle. Run up the right side of the arena past the center marker and do a sliding stop at least twenty feet (six meters) from the wall or fence. Back up at least ten feet (three meters). Hesitate to demonstrate completion of the pattern.

Pattern A

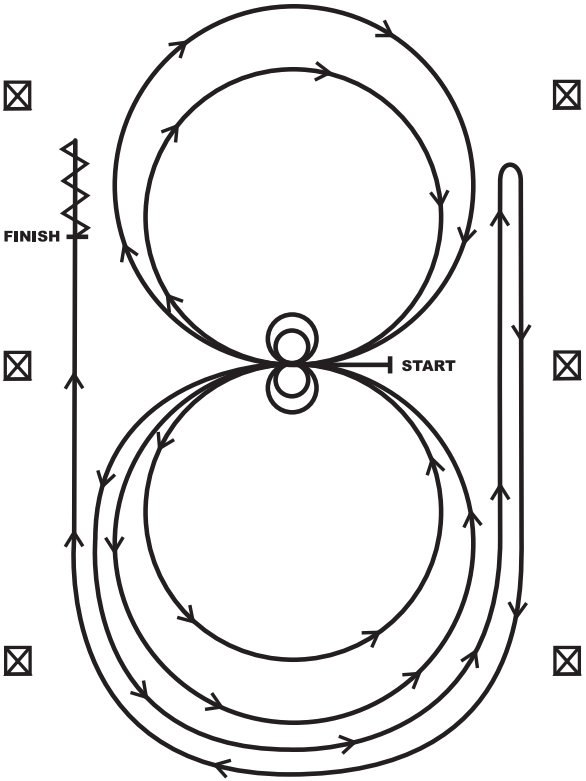

Pattern A

To be used for the Youth 10 & Under Short Stirrup and Para-Reining only.

Horses may walk or jog to the center of the arena. (To assist with the show schedule, show management may require that horses be jogged to center. Show management is responsible for posting this requirement.) Horses must walk or stop prior to starting the pattern. Beginning at the center of the arena facing the left wall or fence.

1. Beginning on the left lead, complete two circles to the left. Stop at the center of the arena. Hesitate.
2. Complete two spins to the left. Hesitate.
3. Beginning on the right lead complete two circles to the right. Stop at the center of the arena. Hesitate.
4. Complete two spins to the right. Hesitate.
5. Beginning on the left lead, go around the end of the arena, run down the right side of the arena past center marker, stop and roll back right.
6. Continue around the end of the arena to run down the left side of the arena past the center marker. Stop. Back up. Hesitate to demonstrate completion of the pattern.

See the Judges' Guide for a summary of other allowances made in the *Handbook*.

Pattern B

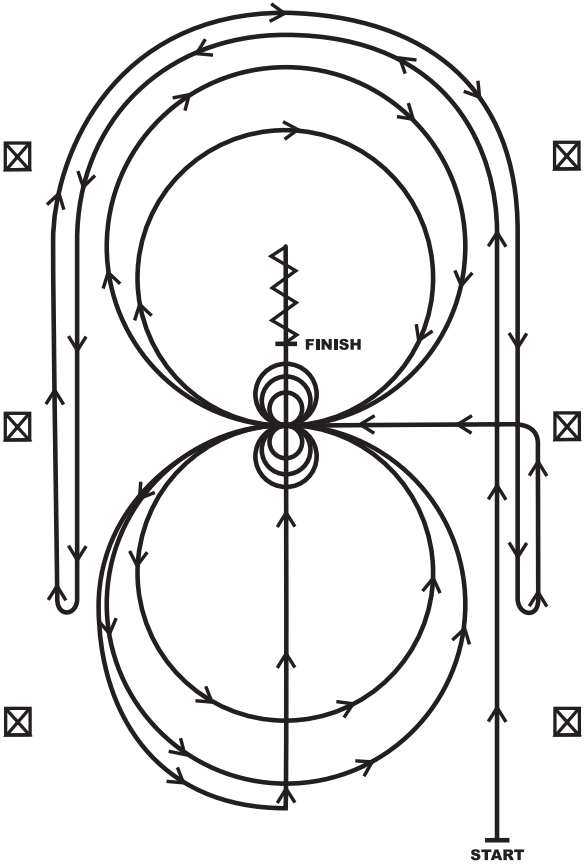

Pattern B

To be used for the Youth 10 & Under Short Stirrup and Para-Reining only.

1. Beginning, lope straight up the right side of the arena, circle the top of the arena run straight down the opposite or left side of the arena past the center mark and do a right rollback—no hesitation.
2. Continue straight up the left side of the arena circle back around the top of the arena run straight down the right side of the arena past the center marker and do a left rollback—no hesitation.
3. Continue up the right side of the arena to the center marker, at the center marker the horse should be on the left lead and complete two circles to the left, one large fast and one small slow. Stop at center. Hesitate.
4. Complete three spins to the left. Hesitate.
5. Complete two circles to the right, one large fast and one small slow. Stop at center. Hesitate.
6. Complete three spins to the right. Hesitate.
7. Begin a large circle to the left, do not close the circle. Continue up the center of the arena past the center marker and do a sliding stop. Back up at least ten feet. Hesitate to demonstrate completion of the pattern.

See the Judges' Guide for a summary of other allowances made in the *Handbook*.